

# STRUKTUR BAJA II

# MODUL 4

## Perencanaan Lantai Kendaraan

Dosen Pengasuh :  
Ir. Thamrin Nasution

Materi Pembelajaran :

CONTOH SOAL PERENCANAAN LANTAI JEMBATAN

Tujuan Pembelajaran :

- Mahasiswa mengetahui dan memahami cara perencanaan lantai jembatan.

### DAFTAR PUSTAKA

- RSNI T-12-2004, *Perencanaan Struktur Beton Untuk Jembatan*.
- RSNI T-02-2005 *Pembebanan Untuk Jembatan*.
- SNI 03-2847-2002 *Tata Cara Perhitungan Struktur Beton Untuk Bangunan Gedung*
- Soemono, Prof., Ir., *ILMU GAYA*, Penerbit Jembatan, Djakarta, 1971.

### UCAPAN TERIMA KASIH

Penulis mengucapkan terima kasih yang sebesar-besarnya kepada pemilik hak cipta photo-photo, buku-buku rujukan dan artikel, yang terlampir dalam modul pembelajaran ini.

Semoga modul pembelajaran ini bermanfaat.

Wassalam

Penulis

Thamrin Nasution

[thamrinnst.wordpress.com](http://thamrinnst.wordpress.com)

[thamrin\\_nst@hotmail.co.id](mailto:thamrin_nst@hotmail.co.id)



## Contoh Soal Perencanaan Lantai Kendaraan

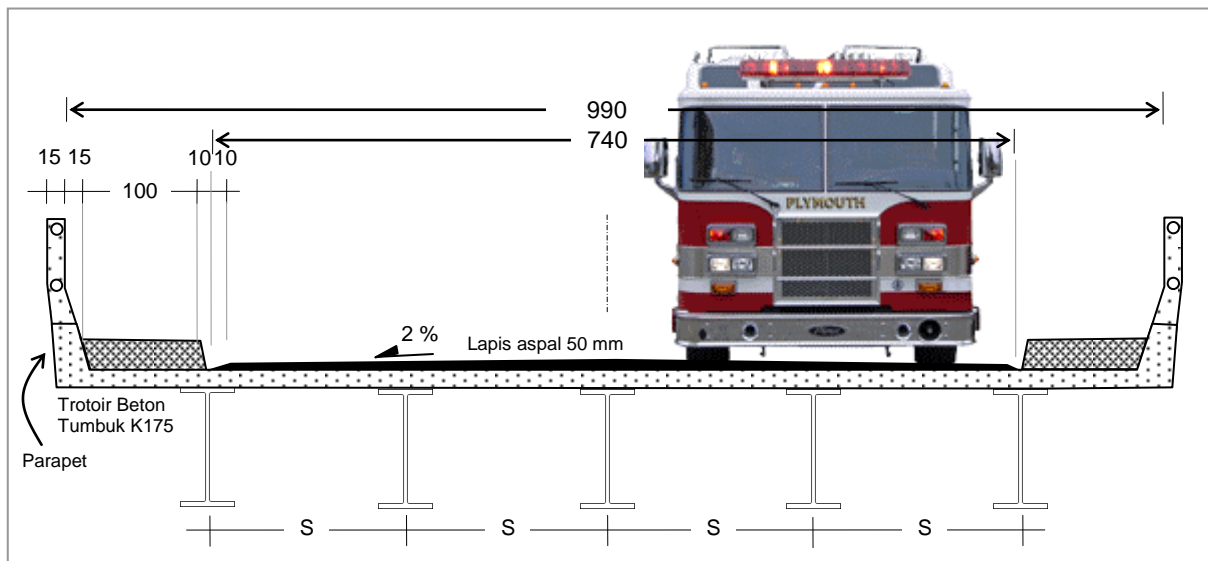

Gambar 1 : Penampang melintang jembatan.

### A). DATA - DATA

#### 1. DATA GEOMETRIS JEMBATAN

Tebal slab lantai jembatan	$t_s = h =$	20,0	cm
Tebal lapisan aspal + overlay	$t_a =$	10,0	cm
Tebal genangan air hujan	$t_h =$	5,0	cm
Jarak antara gelagar baja	$S =$	185,0	cm
Lebar jalur lalu-lintas	$2b_1 =$	740,0	cm
Lebar trotoar	$b_2 =$	100,0	cm
Lebar total jembatan	$b_t =$	990,0	cm
Panjang bentang jembatan	$L =$	31,5	meter

#### 2. DATA MATERIAL

##### a. BETON

Mutu beton, K-250	$=$	250	$\text{kg/cm}^2$	
Kuat tekan beton, $f_c' = 0,83 \text{ K}/10$	$=$	20,8	MPa.	
Modulus Elastis $E_c = 4700 \sqrt{f_c'}$	$=$	21410	MPa.	
Angka Poison, $\mu$	$=$	0,2		
Koefisien muai panjang untuk beton, $\alpha$	$=$	$10^{-5} / ^\circ \text{C} < 30 \text{ MPa.}$		<u>Keterangan</u> Modul 2, hal. 19

##### b. BAJA TULANGAN

Baja ulir,	$f_y =$	390	Mpa	Lihat lampiran.
------------	---------	-----	-----	-----------------

##### c. BERAT JENIS (Specific Gravity)

Berat beton bertulang	$W_c =$	25,0	$\text{kN/m}^3$	<u>Keterangan</u> Modul 2, hal. 4-5
Berat beton tidak bertulang	$W_c' =$	22,0	$\text{kN/m}^3$	
Berat aspal	$W_a =$	22,0	$\text{kN/m}^3$	
Berat jenis air	$W_w =$	9,8	$\text{kN/m}^3$	
Berat baja	$W_s =$	77	$\text{kN/m}^3$	

## B). ANALISA STRUKTUR.

Ditinjau lantai selebar 1,00 meter pada arah memanjang jembatan.

### 1. BERAT SENDIRI (MS)

Faktor beban,

$$\text{Layan, } K_{SMS} = 1,0$$

$$\text{Ultimit, } K_{UMS} = 1,3$$

Keterangan

Modul 2 hal. 5

(RSNI T-02-2005)

No.	Jenis Beban	Tebal m	Berat kN/m <sup>3</sup>	Beban kN/m'
	Lantai jembatan	0.200	25.0	5.00
Berat sendiri			$Q_{MS}$	5.00

### 2. BEBAN MATI TAMBAHAN (MA)

Faktor beban,

$$\text{Layan, } K_{SMA} = 1,0$$

$$\text{Ultimit, } K_{UMA} = 2,0$$

Keterangan

Modul 2 hal. 5

(RSNI T-02-2005)

No.	Jenis Beban	Tebal m	Berat kN/m <sup>3</sup>	Beban kN/m'
1.	Lapisan aspal + overlay	0.100	22.0	2.200
2.	Air hujan	0.050	9.8	0.490
Beban mati tambahan			$Q_{MA}$	2.690

### 3. BEBAN TRUK "T" (TT)

Faktor beban,

$$\text{Layan, } K_{STT} = 1,0$$

$$\text{Ultimit, } K_{UTT} = 1,8$$

Panjang jembatan, = 31,5 meter

Faktor beban dinamis = 30%

Beban hidup pada lantai jembatan berupa beban roda ganda oleh Truk (beban T),

besarnya = 112,5 kN.

Beban Truk menjadi,  $(1 + 0,30) \times 112,5 \text{ kN}$ ,  $P_{TT} = 146,25 \text{ kN}$ .

Keterangan

Modul 2 hal. 11-12

(RSNI T-02-2005)

Modul 2 hal. 14

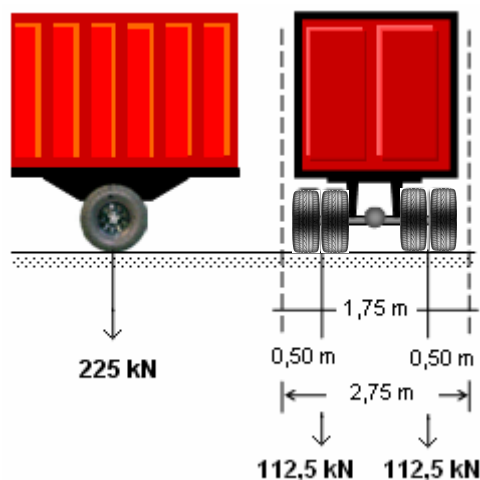

Gambar 2 : Tekanan gandar roda..

#### 4. BEBAN ANGIN (EW)

Keterangan

Koefisien seret,  $C_w = 1,2$

Modul 2 hal. 19-21  
(RSNI T-02-2005)

Keterangan	Notasi	Layan	Ultimit	Satuan
Faktor beban	$K_{EW}$	1,00	1,20	
Kecepatan angin untuk lokasi > 5 km dari pantai,	$V_w$	25	30	m/det

Rumus,

$$T_{EW} = 0,0012 C_w (V_w)^2 \text{ [ kN/m' ]}$$

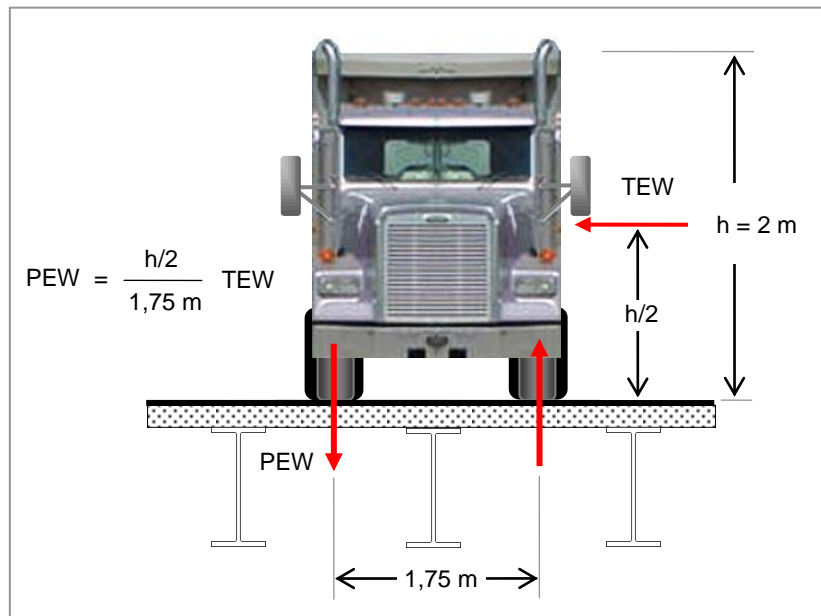

Gambar 3 : Beban garis mendatar ( $T_{EW}$ ) pada bidang samping kendaraan.

Beban garis pada lantai akibat angin,

$$P_{EW} = \frac{h/2}{1,75m} T_{EW} \text{ [ kN/m' ]}$$

Beban angin ( $T_{EW}$ ),

Layan

$$V_{EW} = 25 \text{ m/det}$$

Ultimit

$$V_{EW} = 30 \text{ m/det}$$

$$T_{EW} = 0,0012 \times (1,2) \times (25 \text{ m/det})^2$$

$$T_{EW} = 0,900 \text{ kN/m'}$$

$$T_{EW} = 0,0012 \times (1,2) \times (30 \text{ m/det})^2$$

$$T_{EW} = 1,296 \text{ kN/m'}$$

$$P_{EW} = (1/1,75) \times (0,900 \text{ kN/m'})$$

$$P_{EW} = 0,514 \text{ kN/m'}$$

(panjang ke arah longitudinal 1,00 meter)

$$P_{EW} = (1/1,75) \times (1,296 \text{ kN/m'})$$

$$P_{EW} = 0,741 \text{ kN/m'}$$

#### 5. PENGARUH TEMPERATUR (ET)

Faktor beban,

$$\text{Layan, } K_{STT} = 1,0$$

$$\text{Ultimit, } K_{UTT} = 1,2$$

Keterangan

Modul 2 hal. 18-19  
(RSNI T-02-2005)

Temperatur rata-rata minimum	$T_{min} = 15 \text{ } ^\circ\text{C}$
Temperatur rata-rata maksimum	$T_{maks} = 40 \text{ } ^\circ\text{C}$
Selisih temperatur	$\Delta T = 25 \text{ } ^\circ\text{C}$
Kuat tekan beton	$f_c' = 20,8 \text{ Mpa}$
Koefisien muai akibat temp. untuk $f_c' < 30 \text{ Mpa}$	$\alpha = 10^{-5} / \text{ } ^\circ\text{C}$
Modulus elastisitas untuk $f_c' < 30 \text{ Mpa}$	$E_c = 21410 \text{ MPa}$

## 6. MOMEN PADA LANTAI JEMBATAN

### a. Akibat berat sendiri, ( $Q_{MS}$ ).

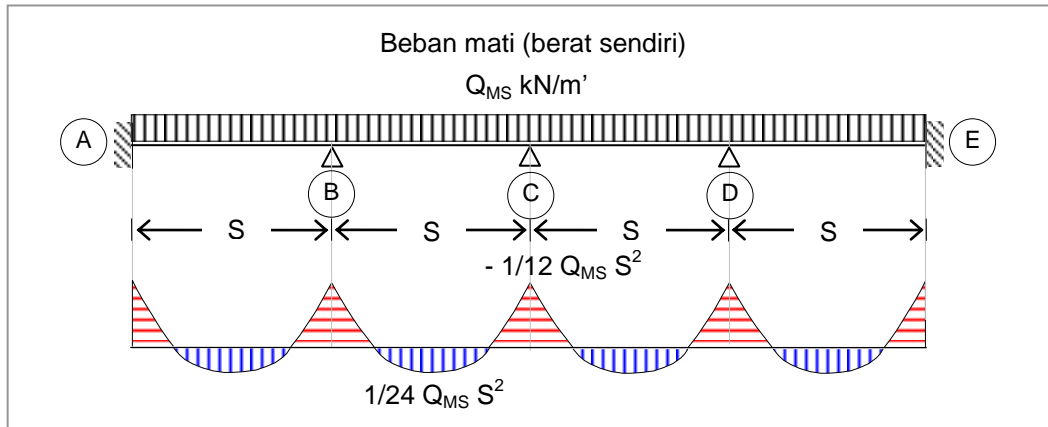

Gambar 4 : Nilai momen lapangan dan tumpuan akibat berat sendiri lantai.

Berat sendiri,  $Q_{MS} = 5 \text{ kN/m'}$ .  
 Jarak gelagar,  $S = 1,850 \text{ m}$   
 Momen tumpuan maksimum,  $M_{MS}^T = 1/12 Q_{MS} S^2 = 1,426042 \text{ kN.m'}$ .  
 Momen lapangan maksimum,  $M_{MS}^L = 1/24 Q_{MS} S^2 = 0,713021 \text{ kN.m'}$ .

### b. Akibat beban mati tambahan, ( $Q_{MA}$ ).

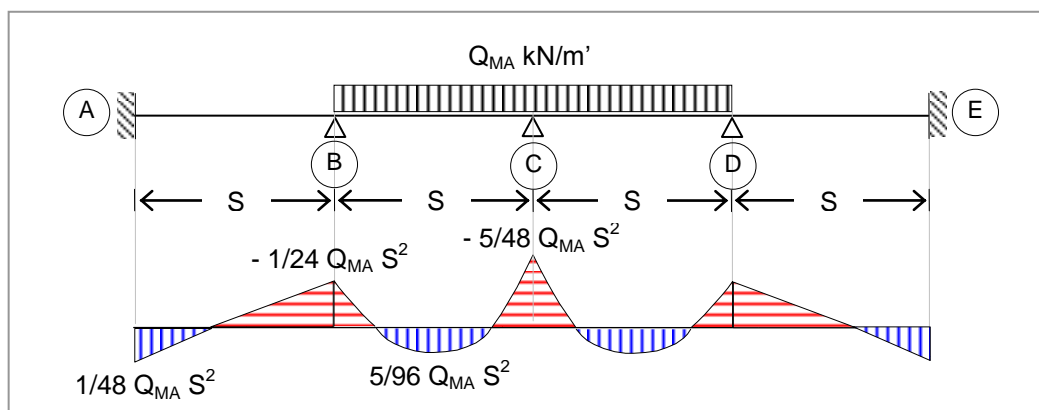

Gambar 5 : Nilai momen lapangan dan tumpuan akibat beban mati tambahan.

Beban mati tambahan,  $Q_{MA} = 2,690 \text{ kN/m'}$ .  
 Jarak gelagar,  $S = 1,850 \text{ m}$   
 Momen tumpuan maksimum,  $M_{MA}^T = 5/48 Q_{MA} S^2 = 0,959013 \text{ kN.m'}$ .  
 Momen lapangan maksimum,  $M_{MA}^L = 5/96 Q_{MA} S^2 = 0,479507 \text{ kN.m'}$ .

c. Akibat beban truk T, ( $P_{TT}$ ).

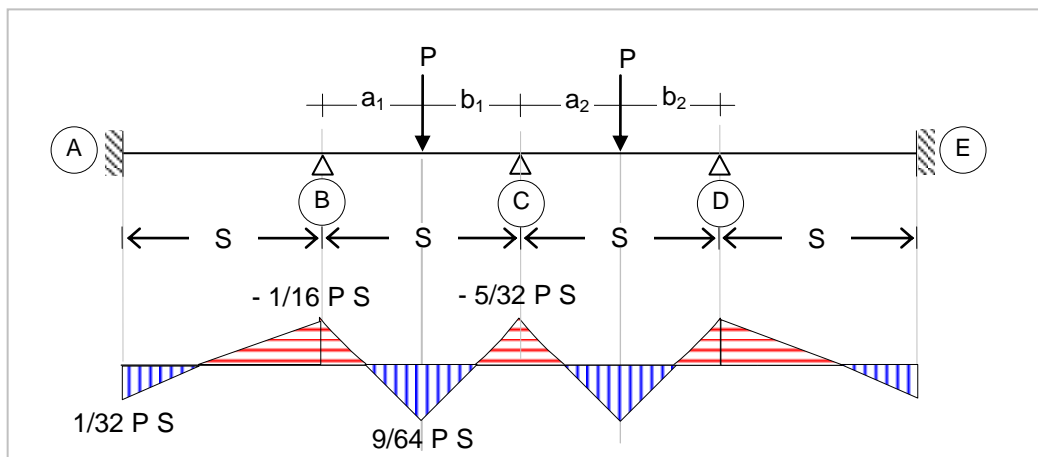

Gambar 6 : Nilai momen lapangan dan tumpuan akibat beban terpusat  $P_{TT}$  dan  $P_{EW}$ .

Beban truk T,  $P_{TT} = 146,250 \text{ kN}$ .  
 Jarak gelagar,  $S = 1,850 \text{ m}$   
 Momen tumpuan maksimum,  $M_{TT}^T = 5/32 P_{TT} S = 42,275391 \text{ kN.m}^{\prime}$ .  
 Momen lapangan maksimum,  $M_{TT}^L = 9/64 P_{TT} S = 38,047852 \text{ kN.m}^{\prime}$ .

d. Akibat beban angin, ( $P_{EW}$ ).

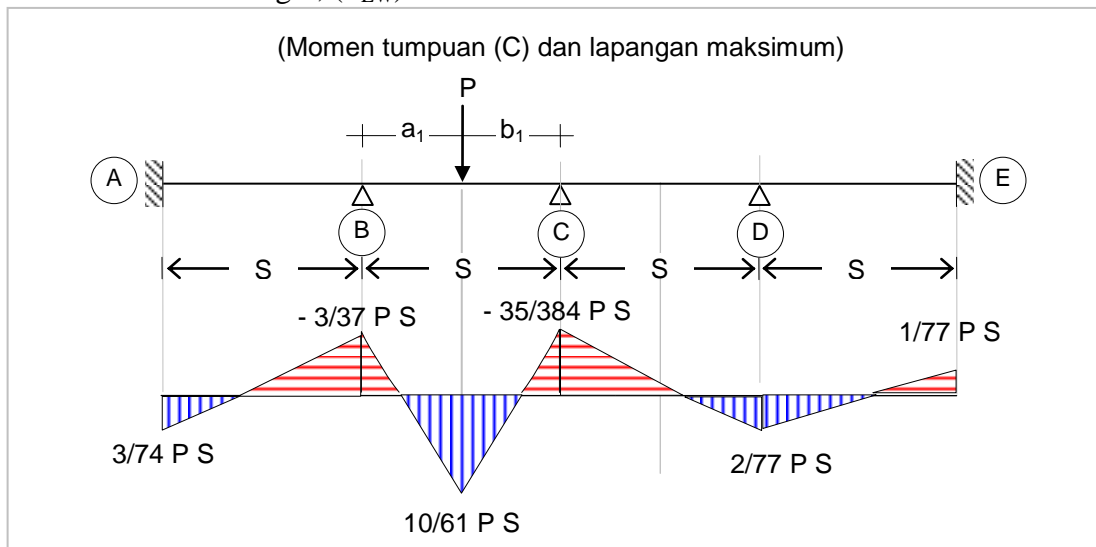

Gambar 7 : Analisa struktur akibat beban angin.

Lihat gambar 7 diatas,  
 Beban kondisi layan,  $P_{EW}^S = 0,514 \text{ kN}$ . (Ditinjau selebar 1,00 meter arah memanjang  
 Beban kondisi ultimit,  $P_{EW}^U = 0,741 \text{ kN}$ . jembatan).  
 Jarak gelagar,  $S = 1,850 \text{ m}$

Kondisi layan,  
 Momen tumpuan maksimum,  $M_{EW}^{TS} = 35/384 P_{EW}^S \cdot S = 0,086671 \text{ kN.m}^{\prime}$ .  
 Momen lapangan maksimum,  $M_{EW}^{LS} = 10/61 P_{EW}^S \cdot S = 0,155885 \text{ kN.m}^{\prime}$ .  
 Kondisi ultimit,  
 Momen tumpuan maksimum,  $M_{EW}^{TU} = 35/384 P_{EW}^U \cdot S = 0,124947 \text{ kN.m}^{\prime}$ .  
 Momen lapangan maksimum,  $M_{EW}^{LU} = 10/61 P_{EW}^U \cdot S = 0,224730 \text{ kN.m}^{\prime}$ .

e. Akibat pengaruh temperatur, (T).

Momen inerti lantai beton,

$$I = \frac{1}{12} b h^3 = \frac{1}{12} \cdot (1000 \text{ mm}) \cdot (200 \text{ mm})^3 = 66666666,7 \text{ mm}^4.$$

Modulus elastisitas,  $E_c = 21410 \text{ MPa}.$

Koefisien muai,  $\alpha = 10^{-5} / ^\circ\text{C}$

Tebal lantai,  $h = 200 \text{ mm}$

Lihat gambar 8 berikut,

Momen tumpuan maksimum,  $M_{ET}^T = \frac{1}{4} \Delta T \cdot \alpha \cdot EI/h = 4,460 \text{ kN.m}'.$

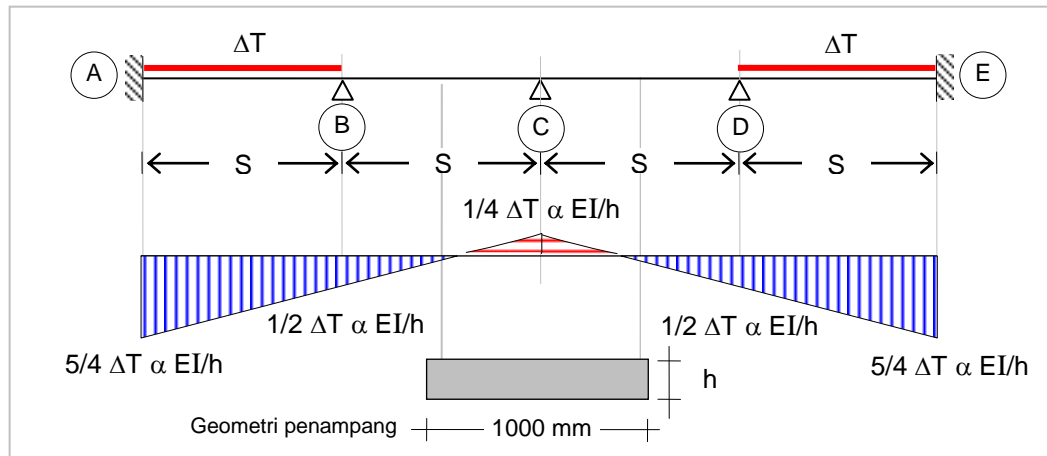

Gambar 8 : Nilai momen tumpuan akibat pengaruh temperatur.

Lihat gambar 9 berikut,

Momen lapangan maksimum,  $M_{ET}^L = \frac{7}{8} \Delta T \cdot \alpha \cdot EI/h = 15,611 \text{ kN.m}'.$

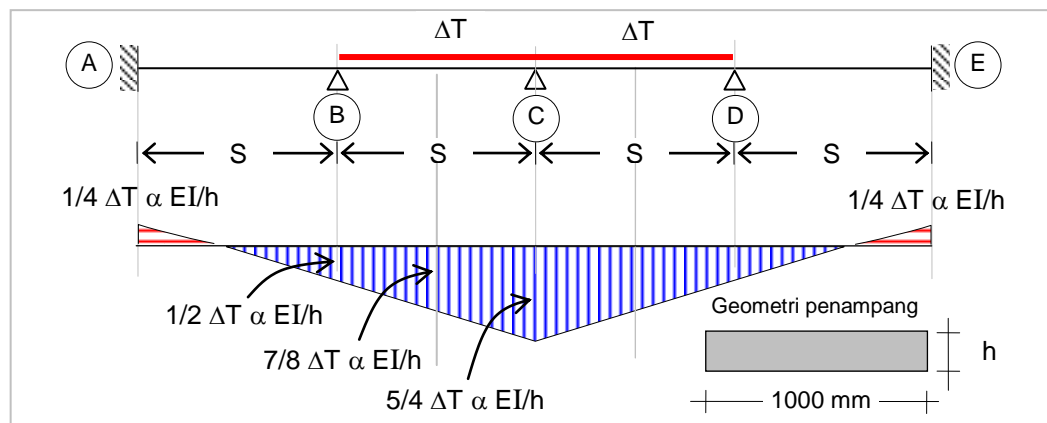

Gambar 9 : Nilai momen lapangan akibat pengaruh temperatur.



f. KOMBINASI MOMEN.

f1). Berikut rekapitulasi momen pada lapangan dan tumpuan,

Tabel 1 : REKAPITULASI MOMEN

No.	Jenis beban	Faktor Beban	Daya Layan	Keadaan Ultimit	M <sub>Lapangan</sub> kN.m'.	M <sub>Tumpuan</sub> kN.m'.
1.	Berat sendiri	K <sub>MS</sub>	1.00	1.30	0.713021	1.426042
2.	B. Mati tambahan	K <sub>MA</sub>	1.00	2.00	0.479507	0.959013
3.	Beban truk T	K <sub>TT</sub>	1.00	1.80	38,047852	42,275391
4.	Pengaruh temp.	K <sub>ET</sub>	1.00	1.20	15.611108	4.460316
5.a	Beban angin	K <sub>EW</sub>	1.00		0,155885	0,086671
5.b	Beban angin	K <sub>EW</sub>		1.20	0,224730	0,124947

Kombinasi momen dilakukan dengan merujuk pada tabel 40 RSNI T-02-2005, atau pada Modul 2 – Pembebanan Jembatan, tabel 20, halaman 24, seperti berikut,

Tabel 20 : Kombinasi beban umum untuk keadaan layan dan ultimit.

A K S I	LAYAN						ULTIMIT					
	1	2	3	4	5	6	1	2	3	4	5	6
<b>Aksi Permanen :</b>												
Berat sendiri												
Beban mati tambahan												
Susut/rangkak												
Pratekan	X	X	X	X	X	X	X	X	X	X	X	X
Pengaruh beban tetap pelaksanaan												
Tekanan tanah												
Penurunan												
<b>Aksi Transien :</b>												
Beban lajur "D" atau beban truk "T"	X	o	o	o	o		X	o	o	o	o	
Gaya rem atau gaya sentrifugal	X	o	o	o	o		X	o	o	o		
Beban pejalan kaki		X						X				
Gesekan perletakan	o	o	X	o	o	o	o	o	o	o	o	o
Pengaruh temperatur	o	o	X	o	o	o	o	o	o	o	o	o
Aliran/hanyutan/batang kayu dan hidrostatis/apung	o		o	X	o	o	o		X	o		o
Beban angin			o	o	X	o	o		o	X		o
<b>Aksi Khusus :</b>												
Gempa												X
Beban tumbukan												
Pengaruh getaran	X	X										
Beban pelaksanaan						X						X
"X" berarti beban yang selalu aktif. "o" berarti beban yang boleh dikombinasi dengan beban aktif, tunggal atau seperti ditunjukkan.	(1) = aksi permanen "X" KBL + beban aktif "X" KBL + 1 beban "o" KBL. (2) = aksi permanen "X" KBL + beban aktif "X" KBL + 1 beban "o" KBL + 0,7 beban "o" KBL. (3) = aksi permanen "X" KBL + beban aktif "X" KBL + 1 beban "o" KBL + 0,5 beban "o" KBL + 0,5 beban "o" KBL.						Aksi permanen "X" KBU + beban aktif "X" KBU + 1 beban "o" KBL.					

f2). KOMBINASI 1 -Momen Lapangan

No.	Jenis beban	Faktor beban		M <sub>Lapangan</sub> kN.m'.	Aksi	Kond. Layan	Aksi	Kond. Ultimit
		Layan	Ultimit			M <sub>S Lapangan</sub> kN.m'.		M <sub>U Lapangan</sub> kN.m'.
1.	Berat sendiri	1,00	1,30	0,713021	X KBL	0,713021	X KBU	0,926927
2.	B. Mati tambahan	1,00	2,00	0,479507	X KBL	0,479507	X KBU	0,959013
3.	Beban truk T	1,00	1,80	38,047852	X KBL	38,047852	X KBU	68,486133
4.	Pengaruh temp.	1,00	1,20	15,611108	o KBL	15,611108	o KBL	15,611108
5.a	Beban angin	1,00		0,155885				
5.b	Beban angin		1,20	0,224730				
					Σ	54,851488	Σ	85,983181

f3). KOMBINASI 1 - Momen Tumpuan

No.	Jenis beban	Faktor beban		M <sub>Tumpuan</sub> kN.m'.	Aksi	Kond. Layan	Aksi	Kond. Ultimit
		Layan	Ultimit			M <sub>S Tumpuan</sub> kN.m'.		M <sub>U Tumpuan</sub> kN.m'.
1.	Berat sendiri	1,00	1,30	1,426042	X KBL	1,426042	X KBU	1,853854
2.	B. Mati tambahan	1,00	2,00	0,959013	X KBL	0,959013	X KBU	1,918026
3.	Beban truk T	1,00	1,80	42,275391	X KBL	42,275391	X KBU	76,095703
4.	Pengaruh temp.	1,00	1,20	4,460316	o KBL	4,460316	o KBL	4,460316
5.a	Beban angin	1,00		0,086671				
5.b	Beban angin		1,20	0,124947				
					Σ	49,120762	Σ	84,327899

f3). KOMBINASI 2 -Momen Lapangan

No.	Jenis beban	Faktor beban		M <sub>Lapangan</sub> kN.m'.	Aksi	Kond. Layan	Aksi	Kond. Ultimit
		Layan	Ultimit			M <sub>S Lapangan</sub> kN.m'.		M <sub>U Lapangan</sub> kN.m'.
1.	Berat sendiri	1,00	1,30	0,713021	X KBL	0,713021	X KBU	0,926927
2.	B. Mati tambahan	1,00	2,00	0,479507	X KBL	0,479507	X KBU	0,959013
3.	Beban truk T	1,00	1,80	38,047852	o KBL	38,047852	o KBL	38,047852
4.	Pengaruh temp.	1,00	1,20	15,611108	0,7KBL	10,927775		
5.a	Beban angin	1,00		0,155885				
5.b	Beban angin		1,20	0,224730				
					Σ	50,168155	Σ	39,933792

f4). KOMBINASI 2 - Momen Tumpuan

No.	Jenis beban	Faktor beban		M <sub>Tumpuan</sub> kN.m'.	Aksi	Kond. Layan	Aksi	Kond. Ultimit
		Layan	Ultimit			M <sub>S Tumpuan</sub> kN.m'.		M <sub>U Tumpuan</sub> kN.m'.
1.	Berat sendiri	1,00	1,30	1,426042	X KBL	1,426042	X KBU	1,853854
2.	B. Mati tambahan	1,00	2,00	0,959013	X KBL	0,959013	X KBU	1,918026
3.	Beban truk T	1,00	1,80	42,275391	o KBL	42,275391	o KBL	42,275391
4.	Pengaruh temp.	1,00	1,20	4,460316	0,7KBL	3,122222		
5.a	Beban angin	1,00		0,086671				
5.b	Beban angin		1,20	0,124947				
					Σ	47,782668	Σ	46,047271

### C). RENCANA TULANGAN PELAT LANTAI KENDERAAN.

Perencanaan berdasarkan *Beban dan Kekuatan Terfaktor* (PBKT) atau kondisi ultimit.

c1). TULANGAN LAPANGAN (Tulangan lentur positif).

Momen rencana (KOMBINASI 1),	Mu	=	85,98318	kN.m'
Mutu beton,	fc'	=	20,8	Mpa.
Mutu baja,	fy	=	390	Mpa.
Tebal pelat lantai kendaraan,	h	=	200	mm.
Tebal selimut beton (diambil),	d'	=	35	mm.
Tebal efektif lantai,	d = (h - d')	=	165	mm.
Lebar lantai yang ditinjau,	b	=	1000	mm.
Diameter tulangan lentur rencana,	dt	=	16	mm
Faktor reduksi kekuatan lentur	φ	=	0,80	
Momen nominal,	Mn = Mu/φ	=	107,478979	kN.m'.

a). Tulangan Lentur.

$$Rn = \frac{Mn}{b \cdot d^2} = \frac{(107,478976 \text{ kN.m}') \times 10^6}{(1000 \text{ mm}) \cdot (165 \text{ mm})^2} = 3,947804 \text{ N/mm}^2$$

Faktor distribusi tegangan beton,  $\beta_1 = 0,85$  (untuk  $f_c' < 30 \text{ MPa}$ ).

$$\rho_b = \beta_1 \cdot 0,85 \cdot \frac{f_c'}{f_y} \cdot \left( \frac{600}{600 + f_y} \right) = (0,85) \cdot (0,85) \cdot \frac{20,8}{390} \cdot \left( \frac{600}{600 + 390} \right)$$

$$\rho_b = 0,023297$$

$$\rho_{maks} = 0,75 \rho_b = 0,75 \cdot (0,023297) = 0,017473$$

$$R_{maks} = \rho_{maks} \cdot f_y \cdot \left( 1 - \frac{1/2 \rho_{maks} \cdot f_y}{0,85 \cdot f_c'} \right)$$

$$R_{maks} = (0,017473) \cdot (390) \cdot \left( 1 - \frac{1/2 \cdot (0,017473) \cdot (390)}{0,85 \cdot (20,8)} \right)$$

$$R_{maks} = 5,498053 \text{ N/mm}^2 > Rn$$

Rasio tulangan yang diperlukan,

$$\rho = \frac{0,85 \cdot f_c'}{f_y} \cdot \left( 1 - \sqrt{1 - \frac{2 \cdot Rn}{0,85 \cdot f_c'}} \right)$$

$$\rho = \frac{0,85 \cdot (20,8)}{390} \cdot \left( 1 - \sqrt{1 - \frac{2 \cdot (3,947804)}{0,85 \cdot (20,8)}} \right) = 0,011614$$

Luas tulangan yang diperlukan,

$$As = \rho \cdot b \cdot d = (0,011614) \cdot (1000 \text{ mm}) \cdot (165 \text{ mm}) = 1916,3 \text{ mm}^2.$$

Diameter tulangan perlu, dengan jarak antara tulangan  $s = 200 \text{ mm}$ ,  $b = 1000 \text{ mm}$ ,

$$d_t = \sqrt{\frac{4 \cdot As \cdot s}{\pi \cdot b}} = \sqrt{\frac{4 \cdot (1916,3 \text{ mm}^2) \cdot (200 \text{ mm})}{(3,14) \cdot (1000 \text{ mm})}} = 22,1 \text{ mm}.$$

Rencanakan tulangan lentur, **D25 - 250**

(Batasan spasi tulangan berdasarkan SNI 2002, ps.9.6.5, adalah 3 x tebal pelat atau 500 mm).

Tulangan dipasang dengan diameter tersedia D25 (lihat lampiran), dan jarak 250 mm, maka luas tulangan terpasang,

$$A_s = \frac{1/4 \pi d_t^2 \cdot b}{s} = \frac{0,25 \cdot (3,14) \cdot (25 \text{ mm})^2 \cdot (1000 \text{ mm})}{250 \text{ mm}}$$

$$= 1962,5 \text{ mm}^2 > 1916,3 \text{ mm}^2 \text{ (memenuhi)}.$$

Kekuatan lentur ultimit penampang (*moment capacity*),

$$M_u = \phi \cdot f_y \cdot \rho \cdot b \cdot d^2 \cdot \left( 1 - 1/2 \frac{\rho \cdot f_y}{0,85 \cdot f_c'} \right)$$

Dimana,

Luas tulangan terpasang,  $A_s = 1962,5 \text{ mm}^2$ .

Ratio tulangan,

$$\rho = \frac{A_s}{b \cdot d} = \frac{1962,6 \text{ mm}^2}{(1000 \text{ mm}) \cdot (165 \text{ mm})} = 0,011894$$

Maka,

$$M_u = \left\{ (0,80) \cdot (390 \text{ MPa}) \cdot (0,011894) \cdot (1000 \text{ mm}) \cdot (165 \text{ mm})^2 \right\} \times$$

$$\left( 1 - 1/2 \frac{(0,011894) \cdot (390 \text{ MPa})}{0,85 \cdot (20,8 \text{ MPa})} \right)$$

$$= \{ 101029500 \text{ N.mm} \} \times [0,868500741] = 87744195 \text{ N.mm}$$

$$M_u = 87,744 \text{ kN.m} > M_u = 85,983181 \text{ kN.m (memenuhi)}.$$

b). Tulangan Bagi.

Tulangan bagi yang dipasang pada arah memanjang jembatan,

$$A_s' = 50\% A_s = 50\% \cdot (1916,3 \text{ mm}^2) = 958,14 \text{ mm}^2.$$

Diameter tulangan perlu, dengan jarak antara tulangan  $s = 250 \text{ mm}$ ,  $b = 1000 \text{ mm}$ ,

$$d_t = \sqrt{\frac{4 \cdot A_s \cdot s}{\pi \cdot b}} = \sqrt{\frac{4 \cdot (958,14 \text{ mm}^2) \cdot (250 \text{ mm})}{(3,14) \cdot (1000 \text{ mm})}} = 17,5 \text{ mm}.$$

Gunakan diameter tulangan bagi, D19 – 250 mm.

c 2). TULANGAN TUMPUAN (Tulangan lentur negatip).

Momen rencana (KOMBINASI 1),	$M_u$	=	84,327900	kN.m'.
Mutu beton,	$f_c'$	=	20,8	Mpa.
Mutu baja,	$f_y$	=	390	Mpa.
Tebal pelat lantai kendaraan,	$h$	=	200	mm.
Tebal selimut beton (diambil),	$d'$	=	35	mm.
Tebal efektif lantai,	$d = (h - d')$	=	165	mm.
Lebar lantai yang ditinjau,	$b$	=	1000	mm.

Diameter tulangan lentur rencana,  $d_t = 16$  mm  
 Faktor reduksi kekuatan lentur  $\phi = 0,80$   
 Momen nominal,  $M_n = M_u/\phi = 105,409875$  kN.m'.  
 a). Tulangan Lentur.

$$R_n = \frac{M_n}{b \cdot d^2} = \frac{(105,409875 \text{ kN.m}') \times 10^6}{(1000 \text{ mm}) \cdot (165 \text{ mm})^2} = 3,871804 \text{ N/mm}^2$$

Faktor distribusi tegangan beton,  $\beta_1 = 0,85$  (untuk  $f_c' < 30$  MPa).

$$\rho_b = \beta_1 \cdot 0,85 \cdot \frac{f_c'}{f_y} \cdot \left( \frac{600}{600 + f_y} \right) = (0,85) \cdot (0,85) \cdot \frac{20,8}{390} \cdot \left( \frac{600}{600 + 390} \right)$$

$$\rho_b = 0,023297$$

$$\rho_{maks} = 0,75 \rho_b = 0,75 \cdot (0,023297) = 0,017473$$

$$R_{maks} = \rho_{maks} \cdot f_y \cdot \left( 1 - \frac{1/2 \rho_{maks} \cdot f_y}{0,85 \cdot f_c'} \right)$$

$$R_{maks} = (0,017473) \cdot (390) \cdot \left( 1 - \frac{1/2 \cdot (0,017473) \cdot (390)}{0,85 \cdot (20,8)} \right)$$

$$R_{maks} = 5,498053 \text{ N/mm}^2 > R_n$$

Rasio tulangan yang diperlukan,

$$\rho = \frac{0,85 \cdot f_c'}{f_y} \cdot \left( 1 - \sqrt{1 - \frac{2 \cdot R_n}{0,85 \cdot f_c'}} \right)$$

$$\rho = \frac{0,85 \cdot (20,8)}{390} \cdot \left( 1 - \sqrt{1 - \frac{2 \cdot (3,871804)}{0,85 \cdot (20,8)}} \right) = 0,011353$$

Luas tulangan yang diperlukan,

$$A_s = \rho \cdot b \cdot d = (0,011353) \cdot (1000 \text{ mm}) \cdot (165 \text{ mm}) = 1873,2 \text{ mm}^2.$$

Diameter tulangan perlu, dengan jarak antara tulangan  $s = 200$  mm,  $b = 1000$  mm,

$$d_t = \sqrt{\frac{4 \cdot A_s \cdot s}{\pi \cdot b}} = \sqrt{\frac{4 \cdot (1873,2 \text{ mm}^2) \cdot (200 \text{ mm})}{(3,14) \cdot (1000 \text{ mm})}} = 21,8 \text{ mm}$$

Rencanakan tulangan lentur, **D22 – 200 mm**

Tulangan dipasang dengan diameter tersedia D22 (lihat lampiran), dan jarak 200 mm, maka luas tulangan terpasang,

$$A_s = \frac{1/4 \pi d_t^2 \cdot b}{s} = \frac{0,25 \cdot (3,14) \cdot (22 \text{ mm})^2 \cdot (1000 \text{ mm})}{200 \text{ mm}}$$

$$= 1899,7 \text{ mm}^2 > 1873,2 \text{ mm}^2 \text{ (terlalu dekat)}$$

Untuk keamanan, kemudahan pemasangan dan ketersediaan ukuran tulangan,

maka ukuran tulangan tumpuan dibuat sama dengan tulangan lapangan, yaitu D25 – 250 mm, dengan luas tulangan terpasang,  $A_s = 1962,5 \text{ mm}^2 > 1873,2 \text{ mm}^2$ .

Kekuatan lentur ultimit penampang (*moment capacity*),

$$M_u = 87,777 \text{ kN.m} > M_u = 84,327900 \text{ kN.m} \text{ (memenuhi).}$$

b). Tulangan Bagi.

Tulangan bagi yang dipasang pada arah memanjang jembatan,

$$A_s' = 50\% A_s = 50\% \cdot (1873,2 \text{ mm}^2) = 936,6 \text{ mm}^2.$$

Diameter tulangan perlu, dengan jarak antara tulangan  $s = 250 \text{ mm}$ ,  $b = 1000 \text{ mm}$ ,

$$d_t = \sqrt{\frac{4 \cdot A_s \cdot s}{\pi \cdot b}} = \sqrt{\frac{4 \cdot (936,6 \text{ mm}^2) \cdot (200 \text{ mm})}{(3,14) \cdot (1000 \text{ mm})}} = 17,5 \text{ mm}.$$

Gunakan diameter tulangan bagi, D19 – 250 mm.

#### D). PEMERIKSAAN GESER PONS PADA LANTAI

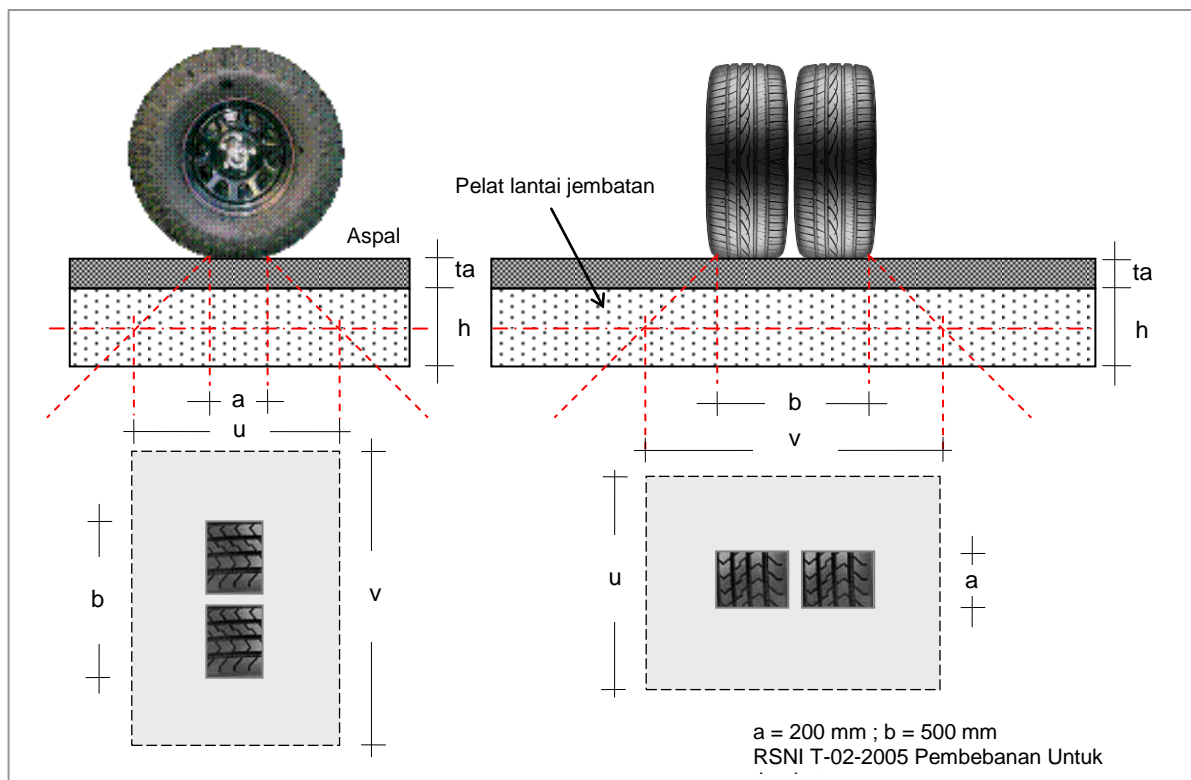

Gambar 9 : Bidang geser pons pada lantai jembatan.

Bidang geser pons,

$$u = a + ta + ta + 1/2h + 1/2h = a + 2 ta + h$$

$$v = b + ta + ta + 1/2h + 1/2h = b + 2 ta + h$$

Dimana,

$$a = 200 \text{ mm} ; b = 500 \text{ mm}$$

$$ta = 100 \text{ mm} ; h = 200 \text{ mm}$$

$$\begin{aligned}
 u &= 200 \text{ mm} + 2 \cdot (100 \text{ mm}) + 200 \text{ mm} = 600 \text{ mm}. \\
 v &= 500 \text{ mm} + 2 \cdot (100 \text{ mm}) + 200 \text{ mm} = 900 \text{ mm} \\
 b' &= 2 u + 2 v = 2 \cdot (600 \text{ mm}) + 2 \cdot (900 \text{ mm}) = 3000 \text{ mm} \\
 d &= 165 \text{ mm} \\
 A_{\text{pons}} &= b' \cdot d = (3000 \text{ mm}) \cdot (165 \text{ mm}) = 495000 \text{ mm}^2.
 \end{aligned}$$

Mutu beton, K-250,  $f_c' = 20,8 \text{ MPa}$ .  
 Tekanan gandar roda,  $P_{TT} = 146,250 \text{ kN}$ .  
 Faktor reduksi kekuatan geser,  $\phi = 0,70$

Kekuatan nominal lantai terhadap geser tanpa tulangan geser,

$$\begin{aligned}
 V_c &= \frac{1}{6} \sqrt{f_c'} \cdot b' \cdot d = \frac{1}{6} \sqrt{20,8 \text{ MPa}} \cdot (3000 \text{ mm}) \cdot (165 \text{ mm}) = 375805 \text{ N} \\
 V_c &= 375,805 \text{ kN}
 \end{aligned}$$

Kekuatan geser terfaktor,

$$\begin{aligned}
 V_u &= \phi \cdot V_c = 0,70 \cdot (375,805 \text{ kN}) = 263,064 \text{ kN} > P_{TT} = 146,250 \text{ kN}. \\
 &\text{Pelat lantai tanpa tulangan geser aman terhadap geser pons.}
 \end{aligned}$$

#### E). GAMBAR RENCANA TULANGAN LENTUR LANTAI JEMBATAN.

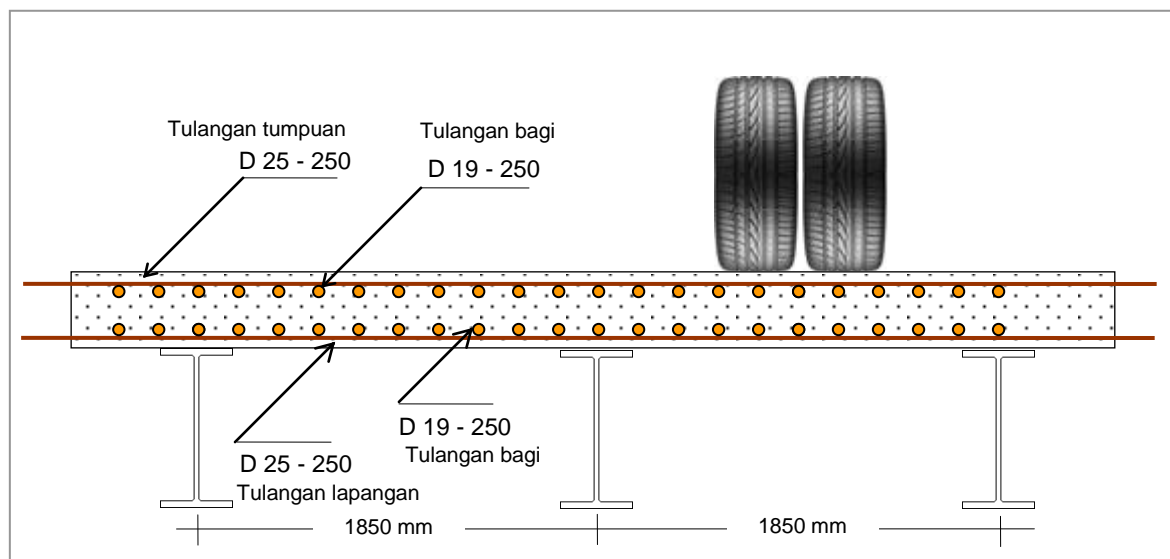

Gambar 10 : Rencana tulangan lentur dan tulangan bagi



Sebagai perbandingan, lihat gambar lantai jembatan berikut,



Gambar 11 : Tulangan lentur pelat lantai jembatan  
(Sumber : youtube)



Gambar 12 : Tulangan parapet



## LAMPIRAN

Daftar besi tulangan produksi PT. GUNUNG GAHAPI BAHARA [www.grdsteel.com](http://www.grdsteel.com), terdiri dari besi polos (*Round/Plain Bar*) dan besi ulir (*Deformed Bar*).

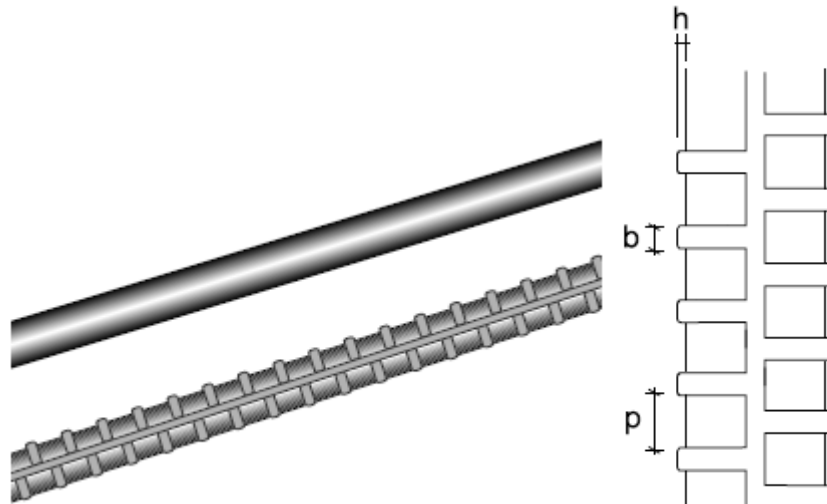

ROUND/PLAIN BAR SIZES (According to JIS G3112)

METRIC SIZE

CODE NO.	UNIT WEIGHT		DIAMETER d	TOLERANCE (mm)	NOMINAL CROSS SECTION	EFFECTIVE PERIMETER
	kg/m					
	Effective	Tolerance	mm		mm <sup>2</sup>	mm
* Ø 7	0.302	7%	7	+ 0.3	38.5	22.0
* Ø 8	0.395	7%	8	+ 0.4	50.3	25.1
* Ø 10	0.617	5%	10	+ 0.4	78.5	31.4
* Ø 12	0.888	5%	12	+ 0.4	113.1	37.7
* Ø 16	1.578	5%	16	+ 0.5	201.1	50.3
* Ø 19	2.226	4%	19	+ 0.5	283.5	59.7
* Ø 22	2.984	4%	22	+ 0.5	380.1	69.1
* Ø 25	3.853	4%	25	+ 0.5	490.9	78.5
Ø 29	5.185	5%	29	+ 0.6	662.5	91.1
Ø 32	6.313	4%	32	+ 0.6	804.2	100.5

DEFORMED BAR SIZES (According To JIS G3112)

METRIC SIZE

CODE NO.	UNIT WEIGHT (kg/m)		EFF. DIA. d	EFF. CROSS SEC. AREA	EFFECTIVE PERIMETER	h	p	b	ANGLE BETWEEN KNOTS
	Effective	Tolerance							
D - 10	0.617	6%	10	78.5	31.4	0.5	7.0 max.	3.9 max.	90°
D - 13	1.042	6%	13	132.7	40.8	0.7	9.1 max.	5.1 max.	90°
* D - 16	1.578	5%	16	201.1	50.3	0.8	11.2 max.	6.3 max.	90°
* D - 19	2.226	5%	19	283.5	59.7	1.0	13.3 max.	7.5 max.	90°
D - 22	2.984	5%	22	380.1	69.1	1.1	15.4 max.	8.6 max.	90°
D - 25	3.853	5%	25	490.9	78.5	1.3	17.5 max.	9.8 max.	90°
D - 29	5.185	4%	29	662.5	91.1	1.4	20.3 max.	20.3 max.	90°
D - 32	6.313	4%	32	804.2	100.5	1.6	22.4 max.	22.4 max.	90°

MECHANICAL PROPERTIES

ACCORDING TO JIS G 3112

TYPE	SYMBOL OF GRADE	YIELD POINT		TENSILE STRENGTH		ELONGATION % min	BENDABILITY		SIZE	
		N/mm <sup>2</sup>		N/mm <sup>2</sup>			Angle	Inside Radius	d	Length
		Min.	Max.	Min.	Max.					
Round Bar	SR 24	235	-	382	520	20	180°	d x 2	5.5 to 25	12
Deformed Bar	SD 40	390	510	560	-	16	180°	d x 2.5	10 to 25	12

SNI 07-2052-2002

**Tabel 1 Ukuran baja tulangan beton polos**

No.	Penamaan	Diameter nominal (d) (mm)	Luas penampang Nominal (L) (cm <sup>2</sup> )	Berat nominal per meter (kg/m)
1.	P.6	6	0,2827	0,222
2.	P.8	8	0,5027	0,395
3.	P.10	10	0,7854	0,617
4.	P.12	12	1,131	0,888
5.	P.14	14	1,539	1,12
6.	P.16	16	2,011	1,58
7.	P.19	19	2,835	2,23
8.	P.22	22	3,801	2,98
9.	P.25	25	4,909	3,85
10.	P.28	28	6,158	4,83
11.	P.32	32	8,042	6,31

CATATAN : P = tulangan polos

**Tabel 2 Ukuran baja tulangan beton sirip**

No	Pena- maan	Dia- meter nominal	Luas Penam- pang nominal	Dia- meter dalam nominal	Tinggi sirip melintang		Jarak sirip melintang (maks)	Lebar rusuk me- manjang (maks)	Berat nominal
		(d)		(d <sub>o</sub> )	min	maks			
		mm		mm	mm	mm			
1	S.6	6	0,2827	5,5	0,3	0,6	4,2	4,7	0,222
2	S.8	8	0,5027	7,3	0,4	0,8	5,6	6,3	0,395
3	S.10	10	0,7854	8,9	0,5	1,0	7,0	7,9	0,617
4	S.13	13	1,327	12,0	0,7	1,3	9,1	10,2	1,04
5	S.16	16	2,011	15,0	0,8	1,6	11,2	12,6	4,58
6	S.19	19	2,835	17,8	1,0	1,9	13,3	14,9	2,23
7	S.22	22	3,801	20,7	1,1	2,2	15,4	17,3	2,98
8	S.25	25	4,909	23,6	1,3	2,5	17,5	19,7	3,85
9	S.29	29	6,625	27,2	1,5	2,9	20,3	22,8	5,18
10	S.32	32	8,042	30,2	1,6	3,2	22,4	25,1	6,31
11	S.36	36	10,18	34,0	1,8	3,6	25,2	28,3	7,99
12	S.40	40	12,57	38,0	2,0	4,0	28,0	31,4	9,88
13	S.50	50	19,64	48,0	2,5	5,0	38,0	39,3	17,4

CATATAN Cara menghitung luas penampang nomnal, keliling nominal, berat nominal dan ukuran sirip adalah sebagai berikut:

a) Luas penampang nominal (L)

$$L = \frac{0,7854 \times d^2}{100} \quad (\text{cm}^2)$$

dibulatkan sampai 4 angka berarti

b) Keliling nominal (K)	$K = 0,3142 \times d$ (mm)	dibulatkan sampai 1 angka desimal
c) Berat = $0,785 \times L$ (kg/m)		dibulatkan sampai 3 angka berarti
d) Jarak sirip melintang maksimum = $0,70 d$		dibulatkan sampai 1 angka desimal
e) Tinggi sirip minimum = $0,05 d$ Tinggi sirip maksimum = $0,10 d$		dibulatkan sampai 1 angka desimal dibulatkan sampai 1 angka desimal
f) Jumlah berat rusuk maksimum = $0,25 K$		dibulatkan sampai 1 angka desimal

CATATAN : S = tulangan sirip (ulir)

**Tabel Sifat mekanis**

Kelas baja tulangan	Nomor batang uji	Uji tarik			Uji lengkung	
		Batas ulur kgf/mm <sup>2</sup> (N/mm <sup>2</sup> )	Kuat tarik kgf/mm <sup>2</sup> (N/mm <sup>2</sup> )	Regangan (%)	Sudut lengkung	Diameter pelengkung
BjTP 24	No. 2	Minimum 24 (235)	Minimum 39 (380)	20	180 <sup>0</sup>	3 x d
	No. 3			24		
BjTP 30	No. 2	Minimum 30 (295)	Minimum 45 (440)	18	180 <sup>0</sup>	d > 16 = 3xd d > 16 = 4xd
	No. 3			20		
BjTP 30	No. 2	Minimum 30 (295)	Minimum 45 (440)	10	180 <sup>0</sup>	d ≤ 16 = 3xd d > 16 = 4xd
	No. 3			18		
BjTP 35	No. 2	Minimum 35 (345)	Minimum 50 (490)	18	180 <sup>0</sup>	d ≥ 16 = 3xd 16 < d ≤ 40 = 4xd d ≥ 40 = 5xd
	No. 3			20		
BjTP 40	No. 2	Minimum 40 (390)	Minimum 57 (500)	16	180 <sup>0</sup>	5 x d
	No. 3			18		
BjTP 50	No. 2	Minimum 50 (490)	Minimum 57 (620)	12	180 <sup>0</sup>	d ≤ 25 = 5xd d > 25 = 6xd
	No. 3			14		
CATATAN	1. Hasil uji lengkung tidak boleh terletak pada sisi luar lengkungan 2. Untuk baja tulangan sirip ≥ S.32 nilai renggang dikurangi 2 % Untuk baja tulangan sirip S.40 dan S.50 dikurangi 4 % dari nilai yang tercantum pada tabel 6. 3. $1 \text{ kgf/mm}^2 = 9,81 \text{ N/mm}^2$					